



Big savings
come in small packages.



Powerhouse
IDLE REDUCTION TECHNOLOGY

**Hybrid
& 120
Models**

Designed to be a better fit for your locomotive, budgetary, and environmental needs.

The PowerHouse™ is a revolutionary idle reduction technology – significantly decreasing the energy wasted through idling. Its unique design allows for easy installation, immediately delivering the benefits of increased fuel savings and reduced noise and air pollution.

» The patent-pending PowerHouse™ Hybrid is powered by either an external AC power source, or directly from the locomotive battery bank. When plugged into an external power source, the Hybrid charges the locomotive batteries.

The PowerHouse™ 120 operates from an external power source.

» Heats and circulates water or coolant through the locomotive engine block and cooling system to maintain a temperature above 100°F, even in the coldest of temperatures via a diesel fired heating unit and coolant pump.

» Compact PowerHouse™ units require significantly less fuel than the idling locomotive engine, leading to lower costs and increased fuel savings for a rapid return on your investment.

» Helps railroads comply with U.S. and global emission standards.

» Designed for convenient set-up, installation, and maintenance – reducing the need for train crew interface.

» Operates in the harshest of conditions with proven dependability.

The PowerHouse™ Heat Exchanger

The heart of the PowerHouse™ is the 90,000 BTU/hr (26kW) diesel-fueled heat exchanger, which provides rapid coolant heating plus rock-solid reliability.



LESS OPERATING COST



SMALLER SIZE



HIGHER HEAT OUTPUT

PowerHouse™ Hybrid

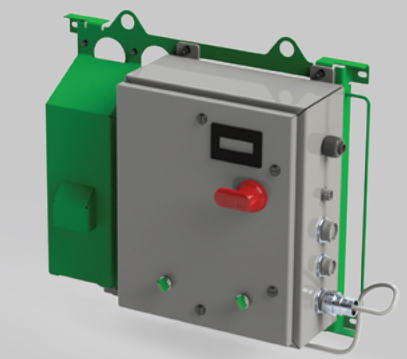
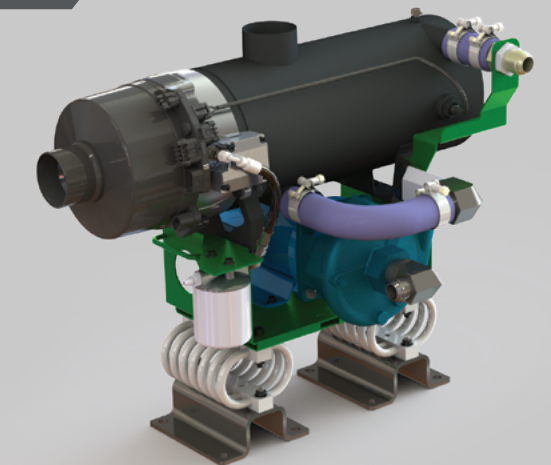

PowerHouse™ 120

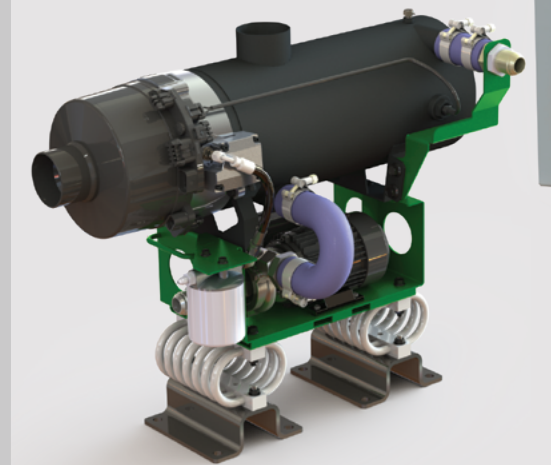

FEATURES AND SPECIFICATIONS

- » Modular components can be mounted up to 20 feet apart – providing additional installation flexibility and occupying a smaller footprint.
- » 90,000 BTU/hr (26kW) diesel burner draws fuel directly from the locomotive fuel tank.
- » Consumes, on average, 0.38 gallons of fuel per hour.
- » Wall mounted control panel.
- » A 24 GPM, 74 VDC electric water pump circulates heated water and/or coolant.
- » Optional 5 GPM oil circulating pump.
- » Remote monitoring capabilities.

CAN OPERATE SOLELY ON BATTERY POWER

- » When external power is not available, the Hybrid can be powered by the locomotive battery bank for up to seven days.* Utilizing this mode, the system can operate in areas where AC power is not available or in the event of a power outage.
- » Charger is active when the system is plugged into an external AC power source.
- » When powered with 120 VAC, the battery charger is capable of outputting 20A.
- » AC power is connected via NEMA 5-15 (120V).
- » Automatically starts when the locomotive prime mover is shut down and stops when it is started again.
- » The only operator intervention required is to plug/unplug the external AC power source.

FEATURES AND SPECIFICATIONS

- » Powered by a standard 120/240 VAC, 5/2.5A external power source.
- » 90,000 BTU/hr (26kW) diesel burner draws fuel directly from the locomotive fuel tank.
- » A 25 GPM, 120/240 VAC water pump circulates heated water and/or coolant.
- » Consumes, on average, 0.38 gallons of fuel per hour.
- » Optional 5 GPM oil circulating pump.
- » Remote monitoring capabilities.

“ WHEN IT COMES TO Idle Reduction Systems, SIZE DOES MATTER. ”

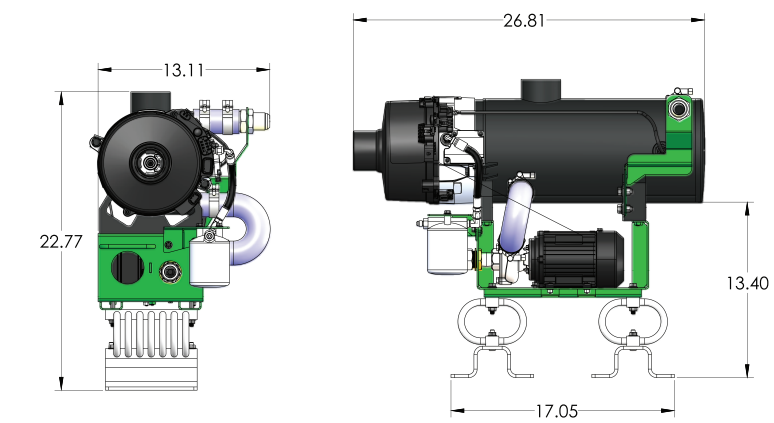
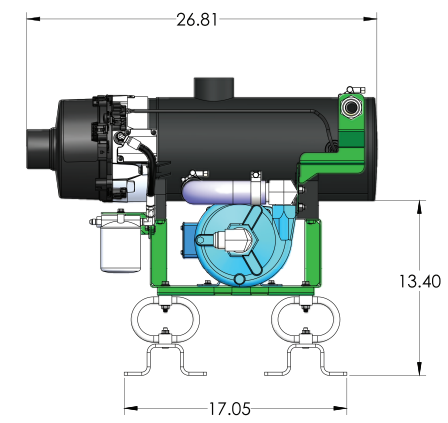
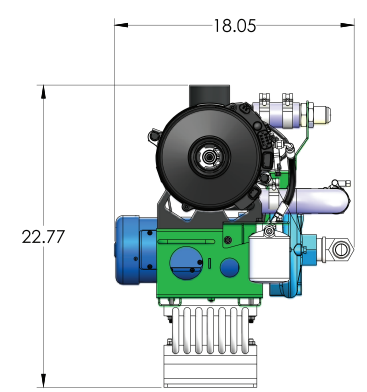

*System runtime depends on battery condition, size, system configuration, additional battery loads, and ambient conditions.



POWERDRIVES.COM

Remote monitoring provides real-time data.

The PowerHouse™ includes standard remote monitoring. With this feature, you can access real-time operating data that shows how your system is performing through the PowerHouse™ dashboard displayed on your computer, tablet, or smart phone.

Key features include:

- » Accessible anytime – anywhere.
- » Real-time maintenance updates and more.
- » Visible fuel savings.



Environmentally sound.

Integral to the design of the PowerHouse™ are the environmental benefits the units provide:

- » Reduction in noise and air pollution.
- » USEPA SmartWay* verified technology that helps railroads meet USEPA mandates.
- » Proactive compliance with Tier 4 EPA clean air standards.
- » 90% emission reduction.

* SmartWay is a public/private collaboration between the United States Environmental Protection Agency (USEPA) and the freight transportation industry that helps shippers, carriers, and logistics companies improve fuel efficiency and save money.



Scan here for more information about the PowerHouse.™

NYSERDA
proves
that the
PowerHouse™
saves
thousands of
gallons of fuel.†



The New York State Energy Research and Development Authority (NYSERDA) conducted a demonstration project on locomotives equipped with the PowerHouse™ idle reduction technology. Over the demonstration period, numerous trains were tested for the amount of fuel used by the PowerHouse™ units during locomotive out-of-service time, compared to the amount of fuel consumed by idling locomotive engines during the same amount of time. The net fuel savings experienced by every train tested numbered in the thousands of gallons.

† PON 2078.